

Costing Summaries for Selected Water Treatment Processes

Alix Montel

Ecole Centrale de Nantes

M. Robin Collins

Department of Civil Engineering

University of New Hampshire

Acknowledgment

Project funded from USEPA to
the

University of New Hampshire
Water Treatment Technology
Assistance Center

Develop Costing Curves for :

- Construction
- Operation and Maintenance

Small Systems

- Limited financial means
- Economy of scale

Economy of Scale

(Clark, 1987)

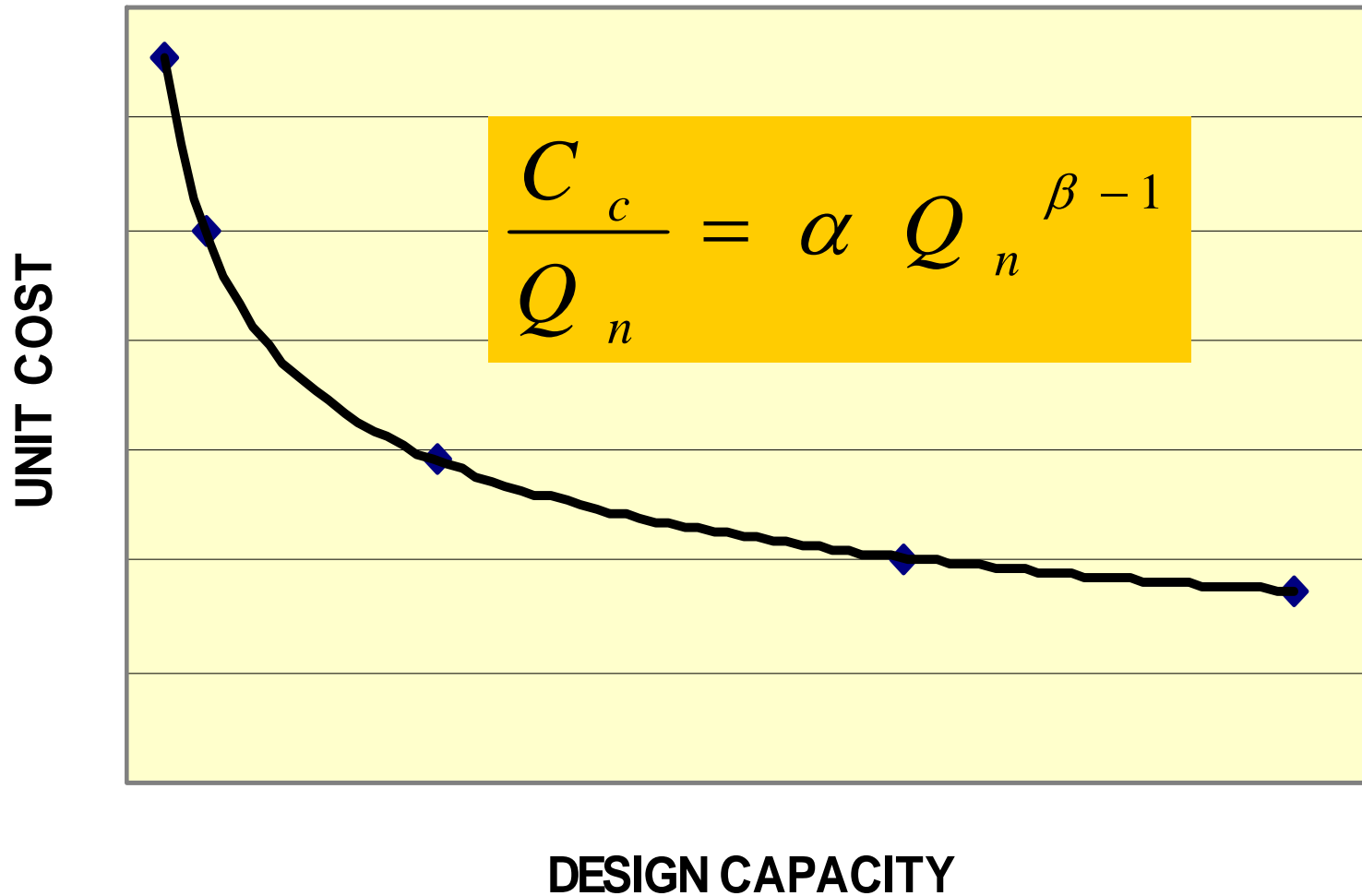

A Reference For :

- Small Water Utility Decision-Makers
- Engineering Consultants
- Facility Operators

Treatments Considered :

- Slow Sand Filtration
- Ceramic Media Pressure Filtration

Slow Sand Filtration

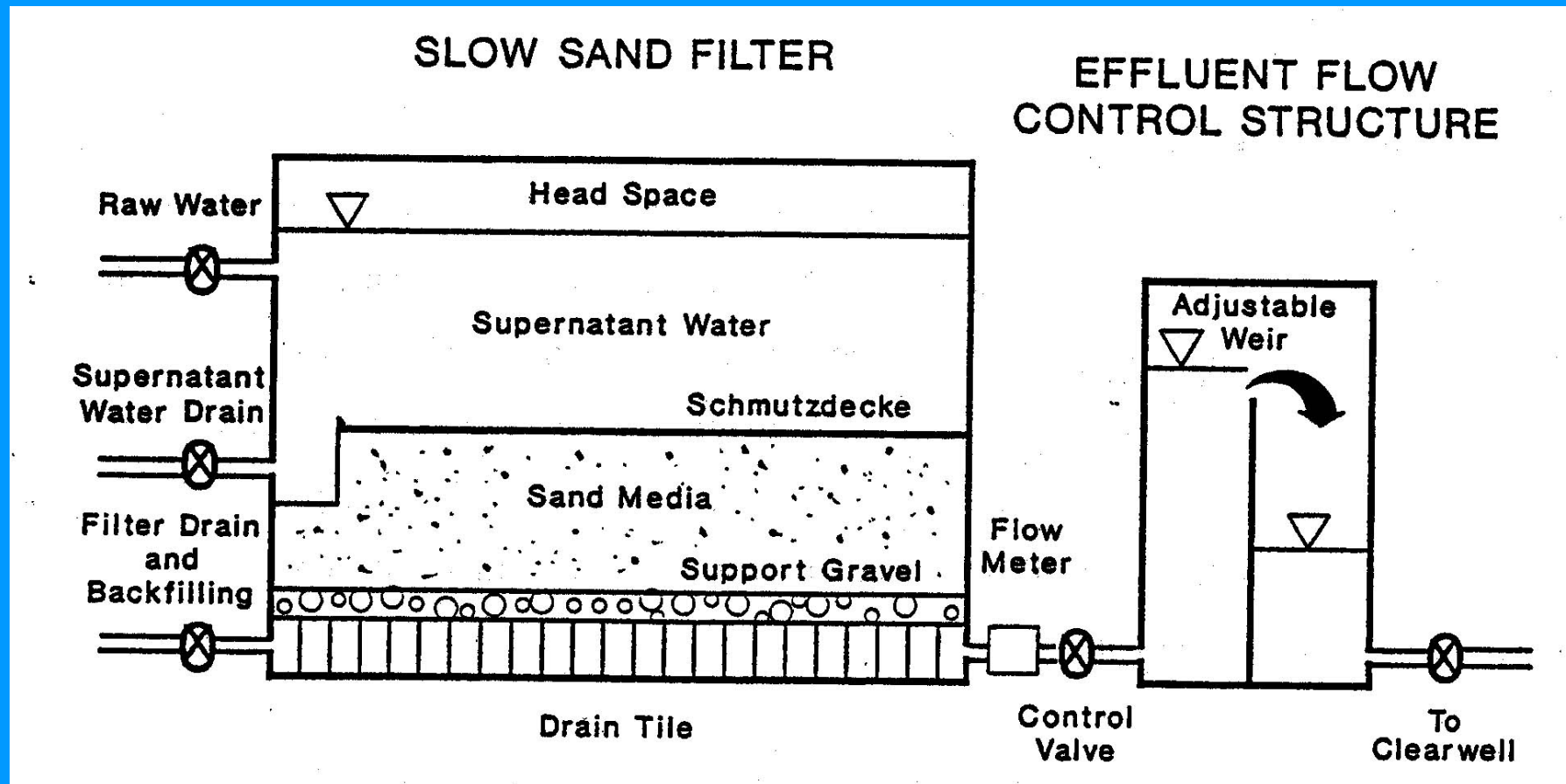

Ceramic Media Filtration

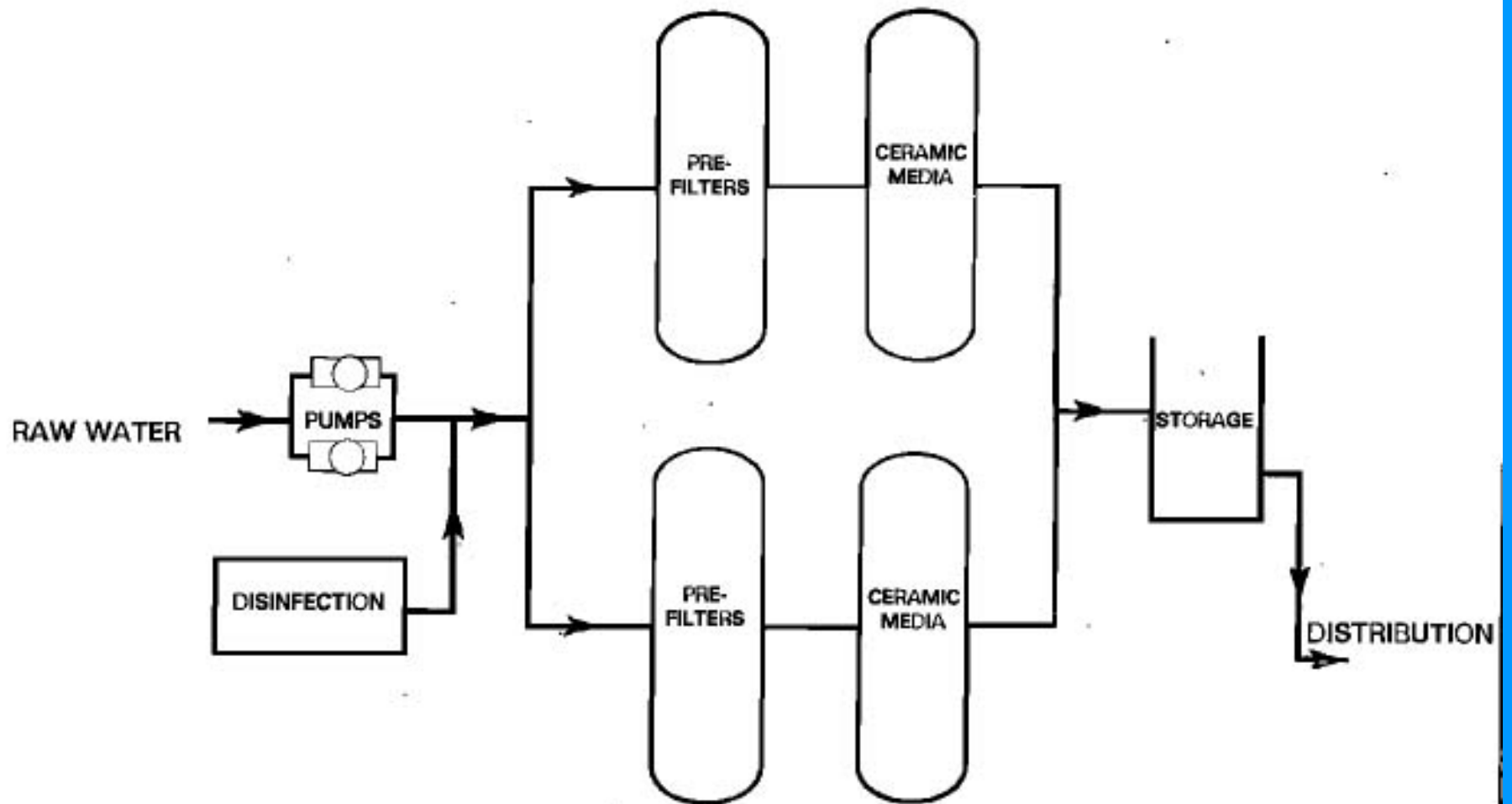

Methodology

Collect Data From:

- Engineering Consulting Companies
- Facility Operators
- Facility Public Works Departments

Questionnaires

- Construction Costs
- O&M Costs
- General Design and Operational Information

Update The Costs for year 2000

- Engineering News-Record Construction Cost Index
- Consumer Prices Index

$$\text{Updated Cost (year } x) = \text{Cost (year } y) \times \frac{\text{Cost Index (year } x)}{\text{Cost Index (year } y)}$$

- Year Index = average of the monthly values of the year

Slow Sand Filtration

Facility	Filter Area (sq.m.)	Design Capacity (mgd)	Year of Construction
West Hartford CT.	46452	50	1920,1960
Springfield MA.		44	1924,1952,1966
Greenfield MA.	1858	2.4	1935
W.Springfield MA.	2787	2	1955
Hatfield MA.	929	1	1997
Derby VT.	754	0.35	1996
Rutland VT.	4682	4.8	1994
McIndoe Falls VT.	82	0.036	1975
Livermore Falls ME.	765	1	1993
Eagle Lake ME.	335	0.3	1993
Winthrop ME.	962	0.6	1993
Mars Hill ME.	279	0.3	1992-94
Madison ME.	1605	1.2	1993
Milo ME.	576	0.45	1995
Newport ME.	564	0.61	1994
Sunapee NH.	491	0.375	1997-98
Newport NH.	976	0.7	1992
Hillsborough NH.		1	1995
Barlett NH.	307	0.34	1996
Gorham NH.	1374	1	1990

20 Slow Sand Filters Surveyed

- 19 of the 20 covered
- design capacity from 0.036 to 50 mgd
- total filter area from 82 to 46,452 m²
- 15 of them built in the 1990s

CONSTRUCTION COSTS

Design Parameter Normalization

- Filter Area

eliminates
differences in
filtration rates
between the plants

- Design capacity

allows to achieve a
comparison with
other technologies

Design Capacity versus Filter Area (design filtration rate)

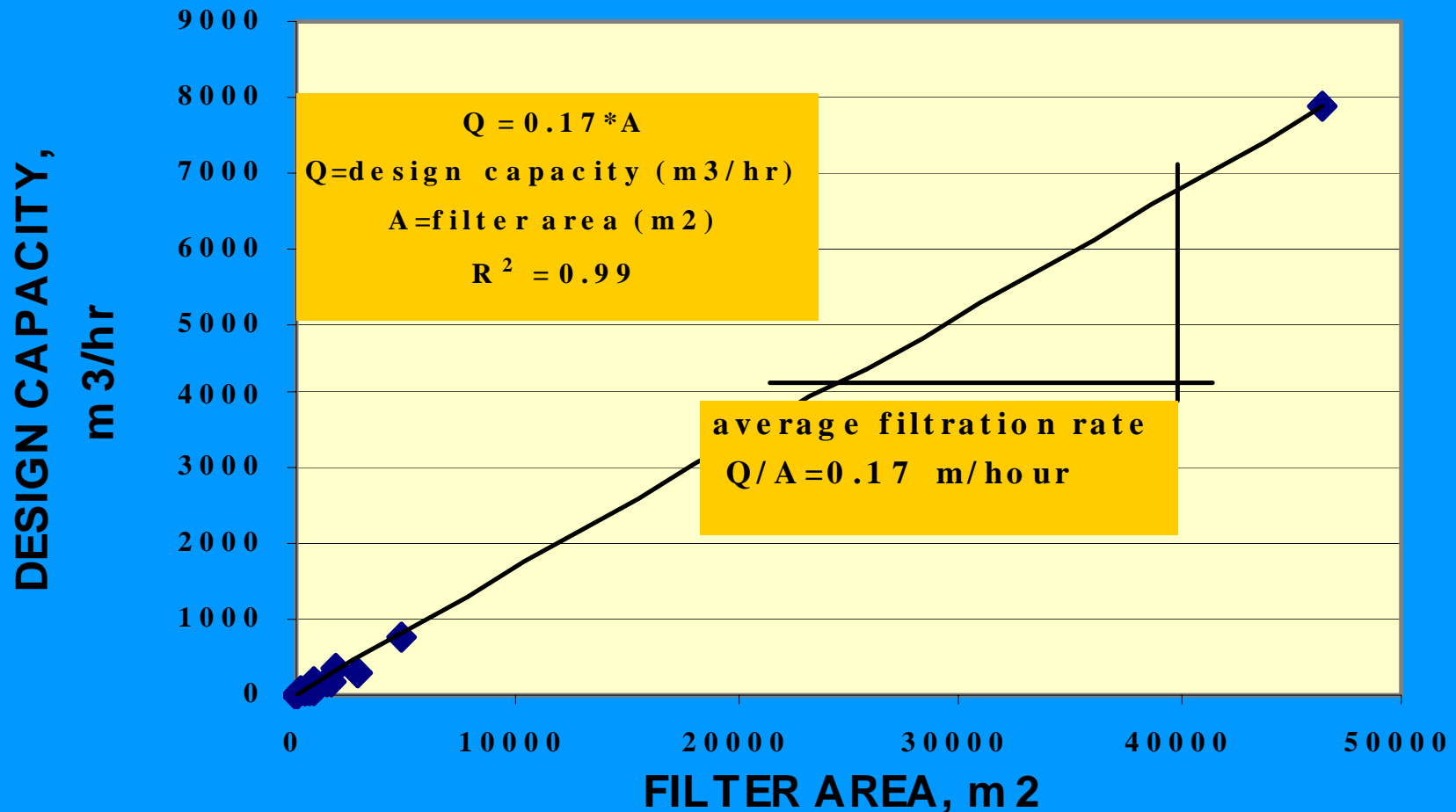

*1000 m³/hr = 6.34 mgd

*Typical Design Value :
0.12m/hr=0.05gpm/sq.ft

Total Cost

(updated for year 2000)

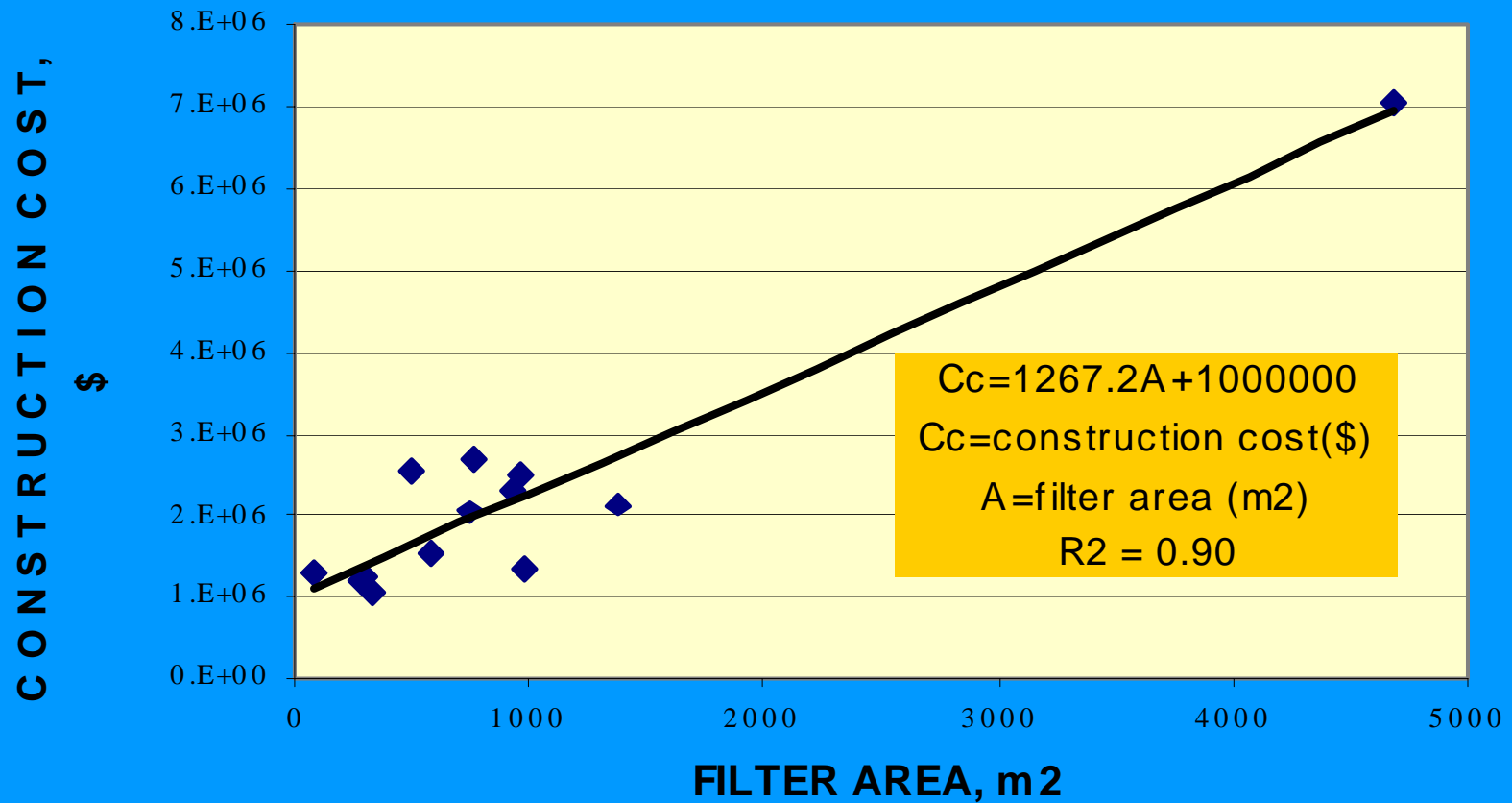

Construction Cost Variability

- Site conditions
- Water storage size variation
- Facility influent and effluent piping

Comparison with a Previous Study

by Berg, Tanner and Shied, *Slow Sand Filtration, ASCE, 1991*

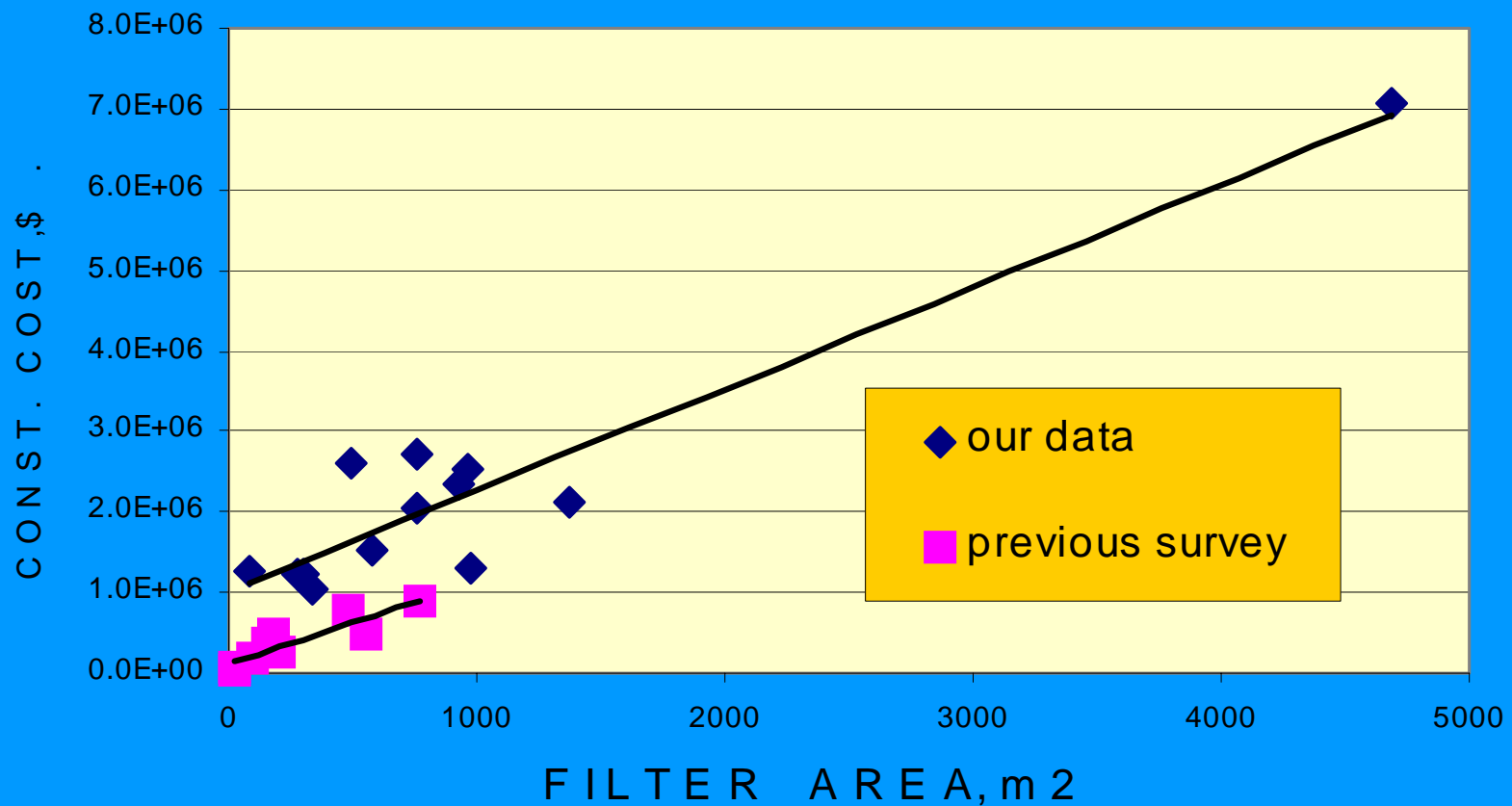

all costs updated for year 2000

Unit Cost

(updated for year 2000)

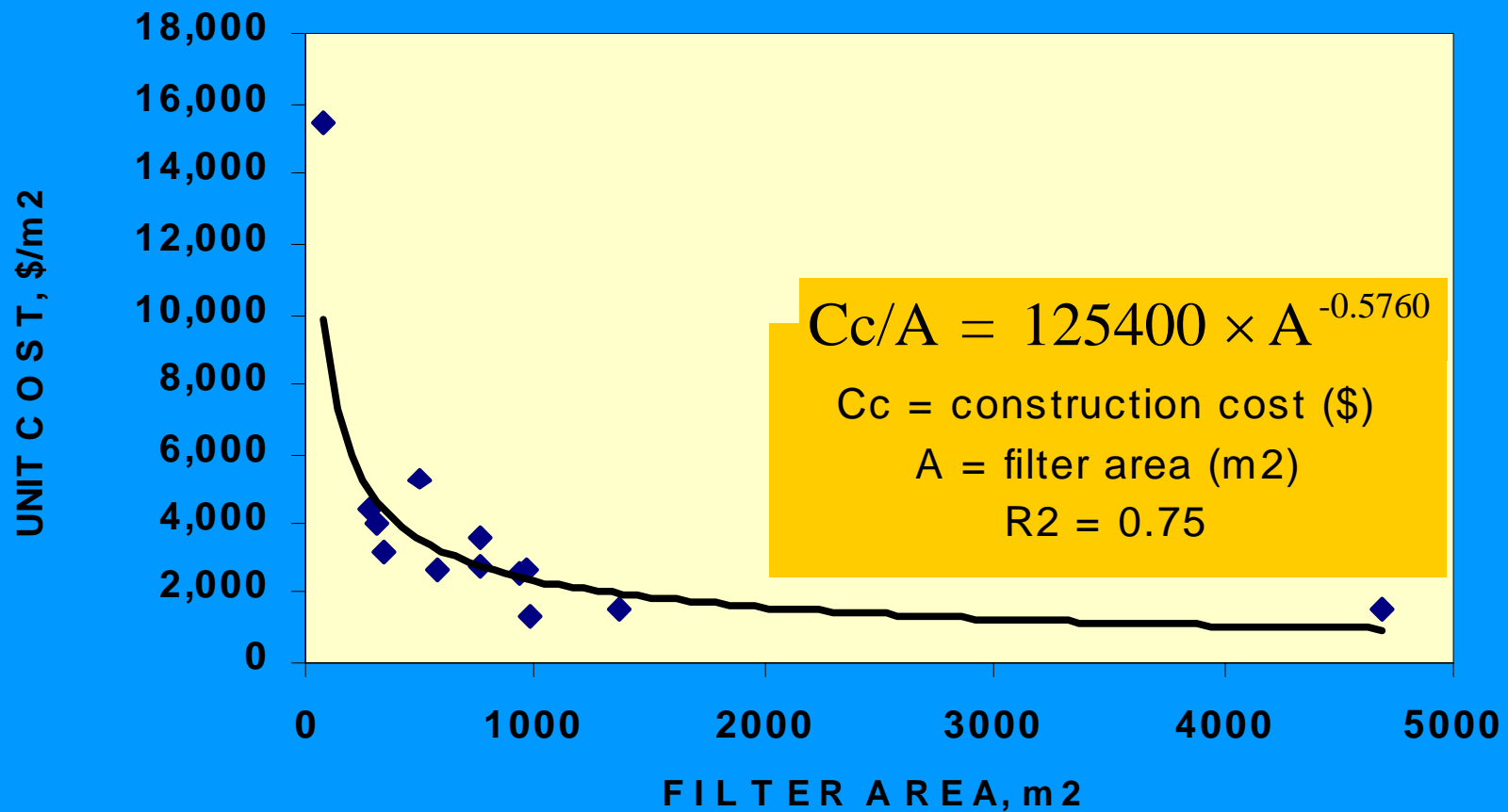

O&M COSTS

Actual Water Flow/Design Capacity

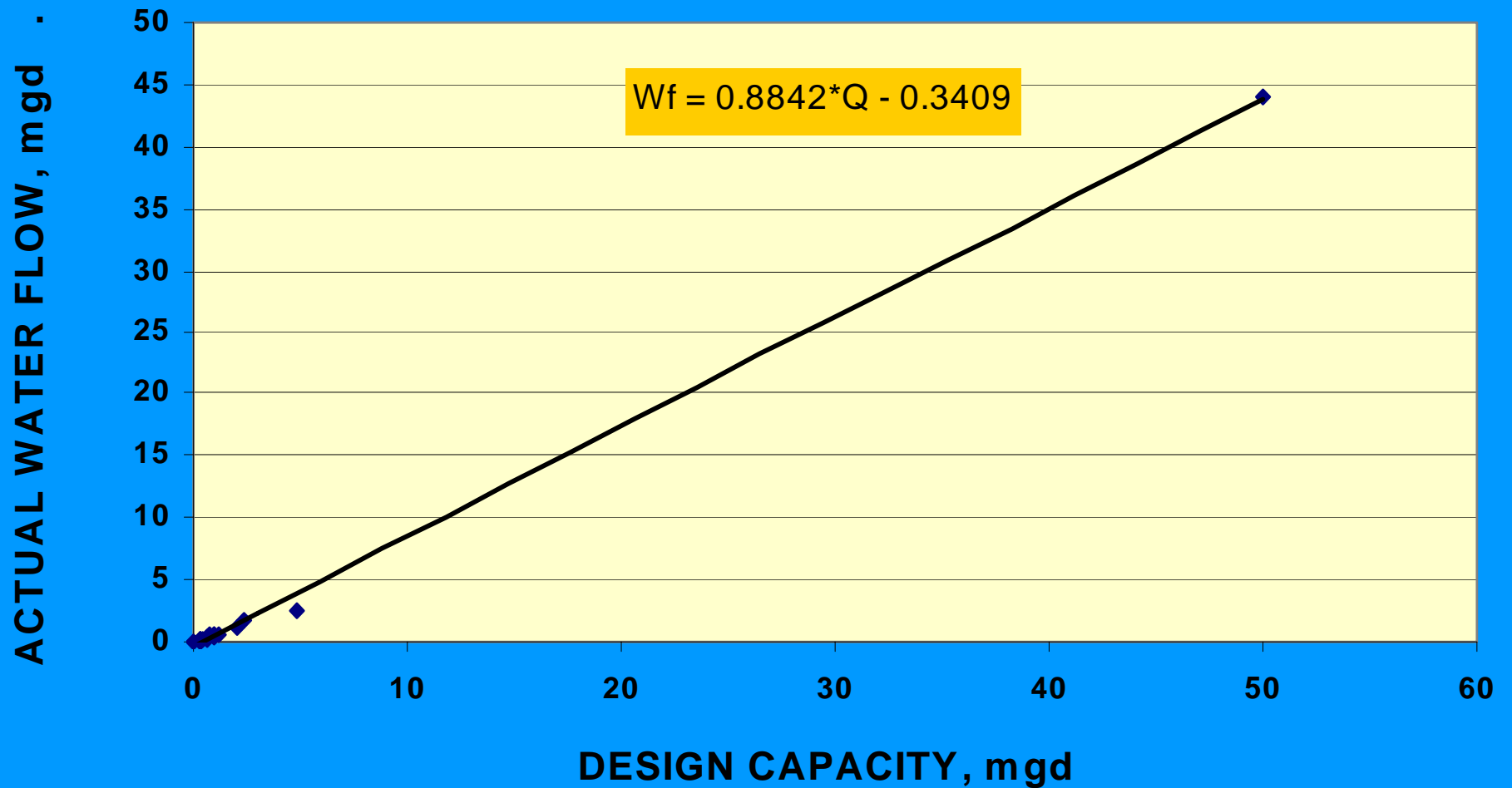

Unit Cost

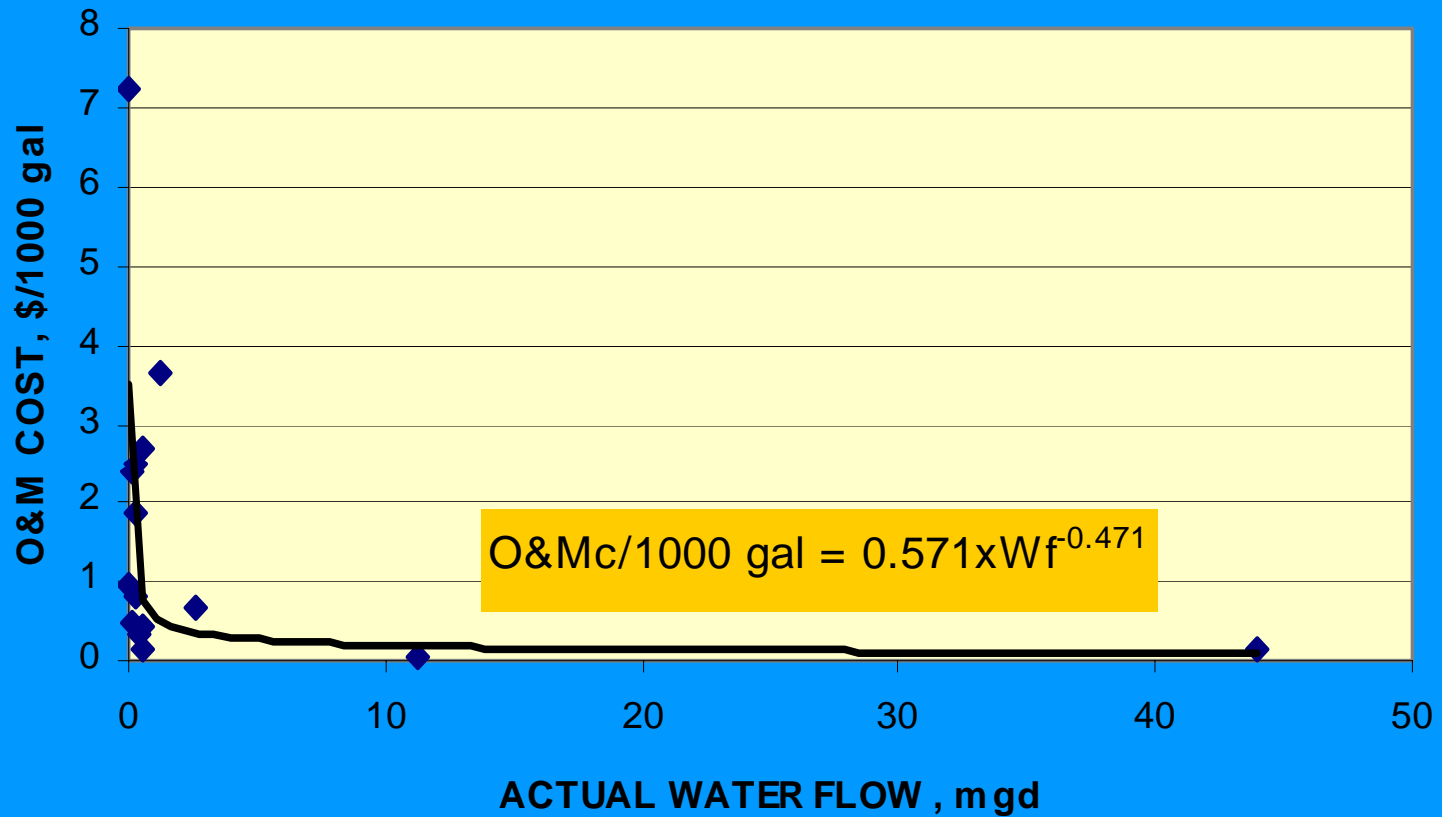

O&Mc = Operation and Maintenance Cost (\$)

Wf = Actual treated water flow (mgd)

R2 = 0.39

Budget Composition

- Chemicals
- Electricity
- Labor
- Sand replacing

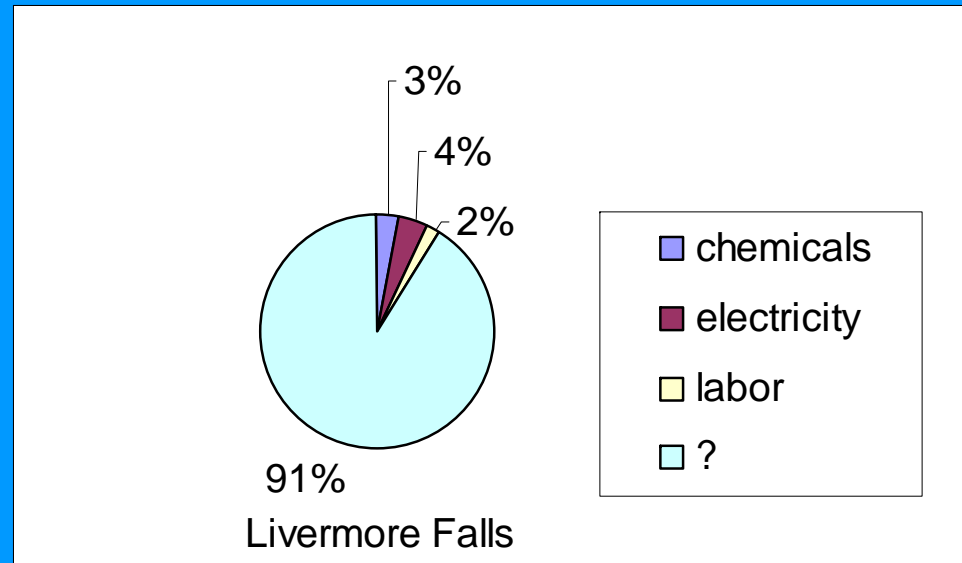

example

Chemicals, Electricity and Labor Cost

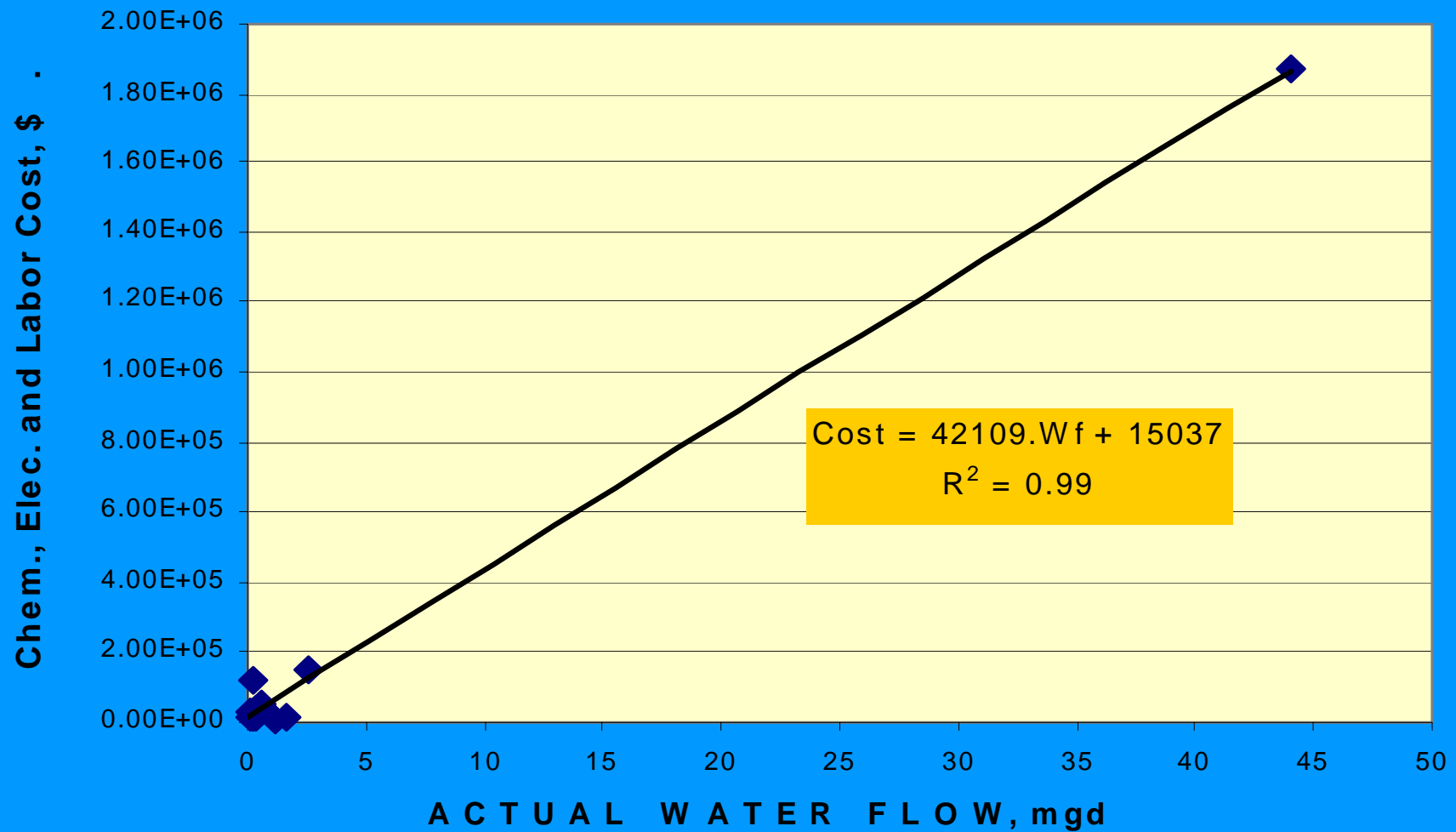

Chemicals, Electricity and Labor Cost (zoom)

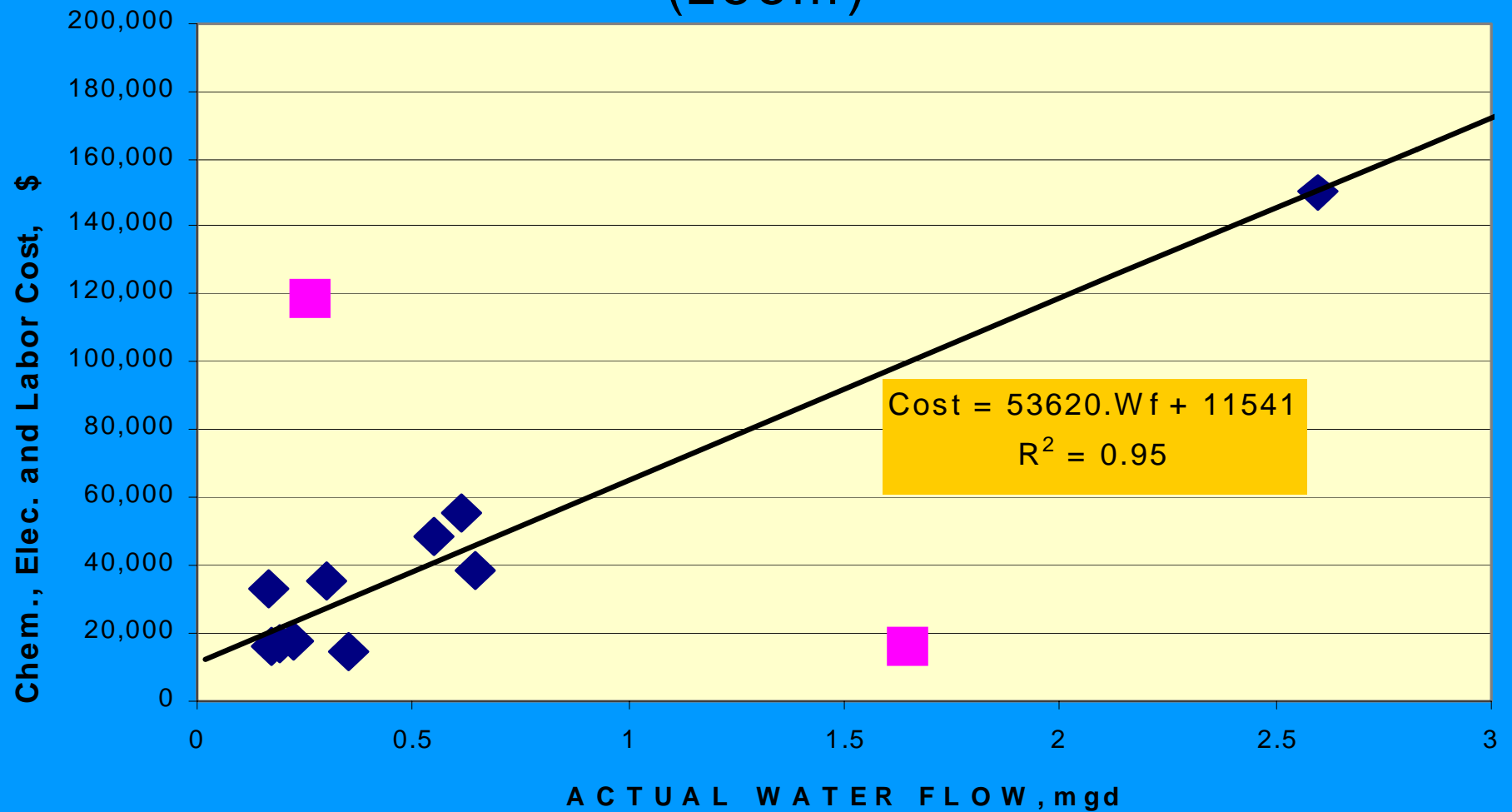

Unit O&M Cost

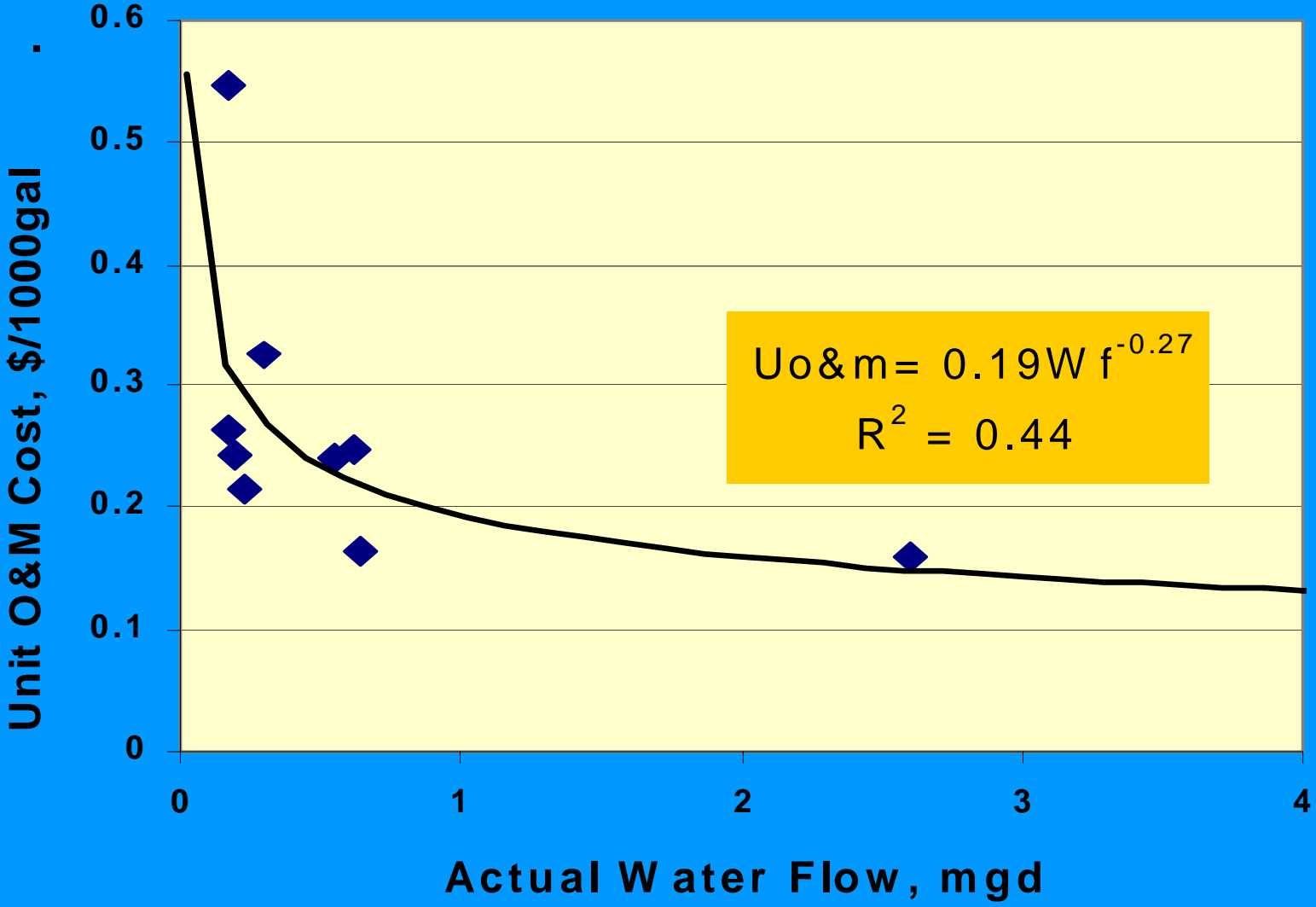

Operation and Maintenance Costs

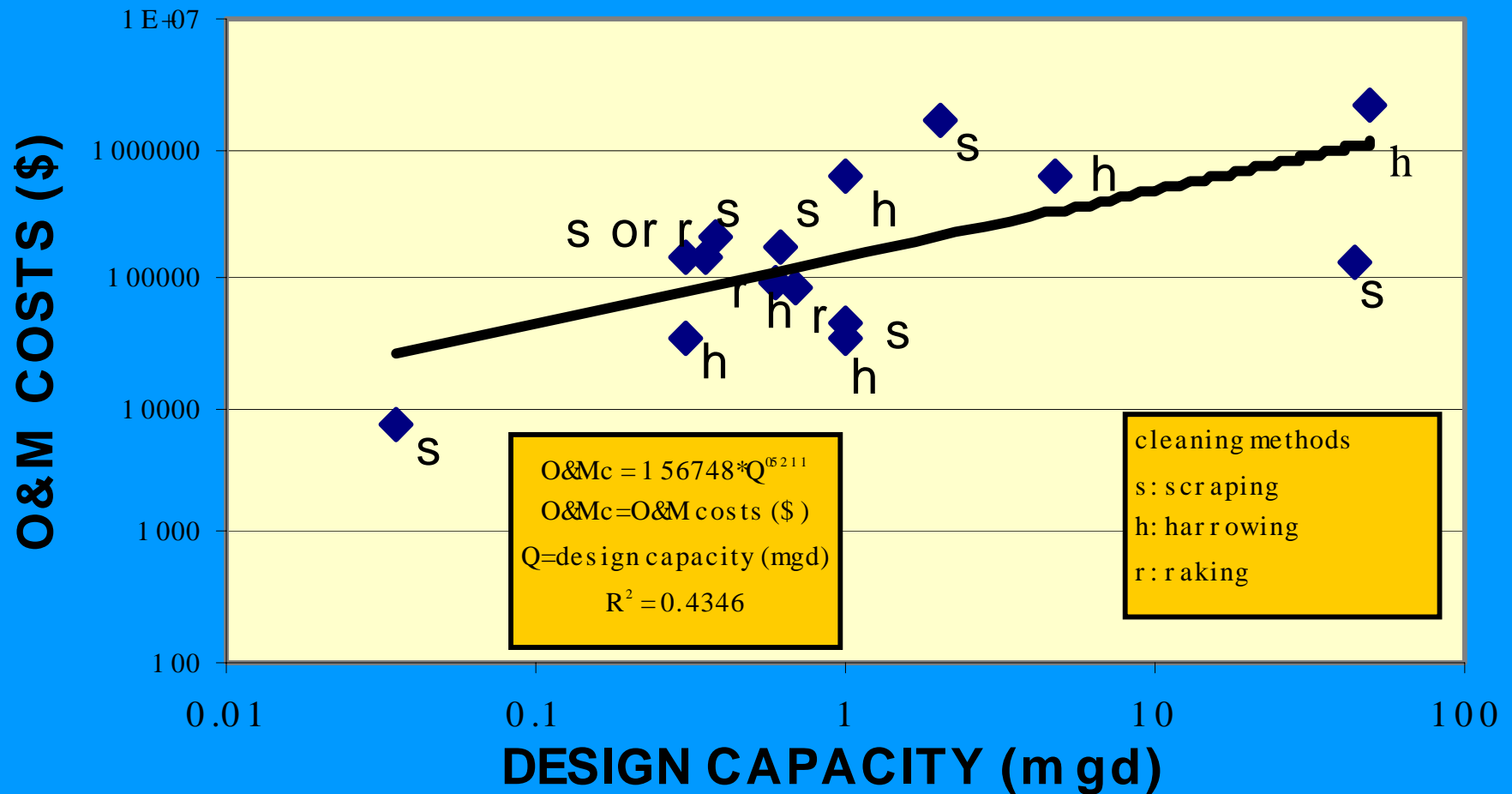

O&M Costs Variability

- Raw water quality
- Wages
- Gravity versus pumping

Ceramic Media Filtration

Ceramic Media Filters

Facilities	Year of construction	Design Capacity (mgd)
Contoocook, NH	1993	0.120
New Hampton, NH	1995	0.060
Swain's Lake, NH	1997	0.060
Goffstown, NH	1996	0.360
Grand Isle, VT	1997	0.178

5 Filters surveyed

- built in the 1990s
- design capacity from 0.06 to 0.36 mgd

Construction Cost

- building cost
 - updated with ENRCCI
- equipment cost
 - updated with CPI

Total Construction Cost Versus Design Capacity

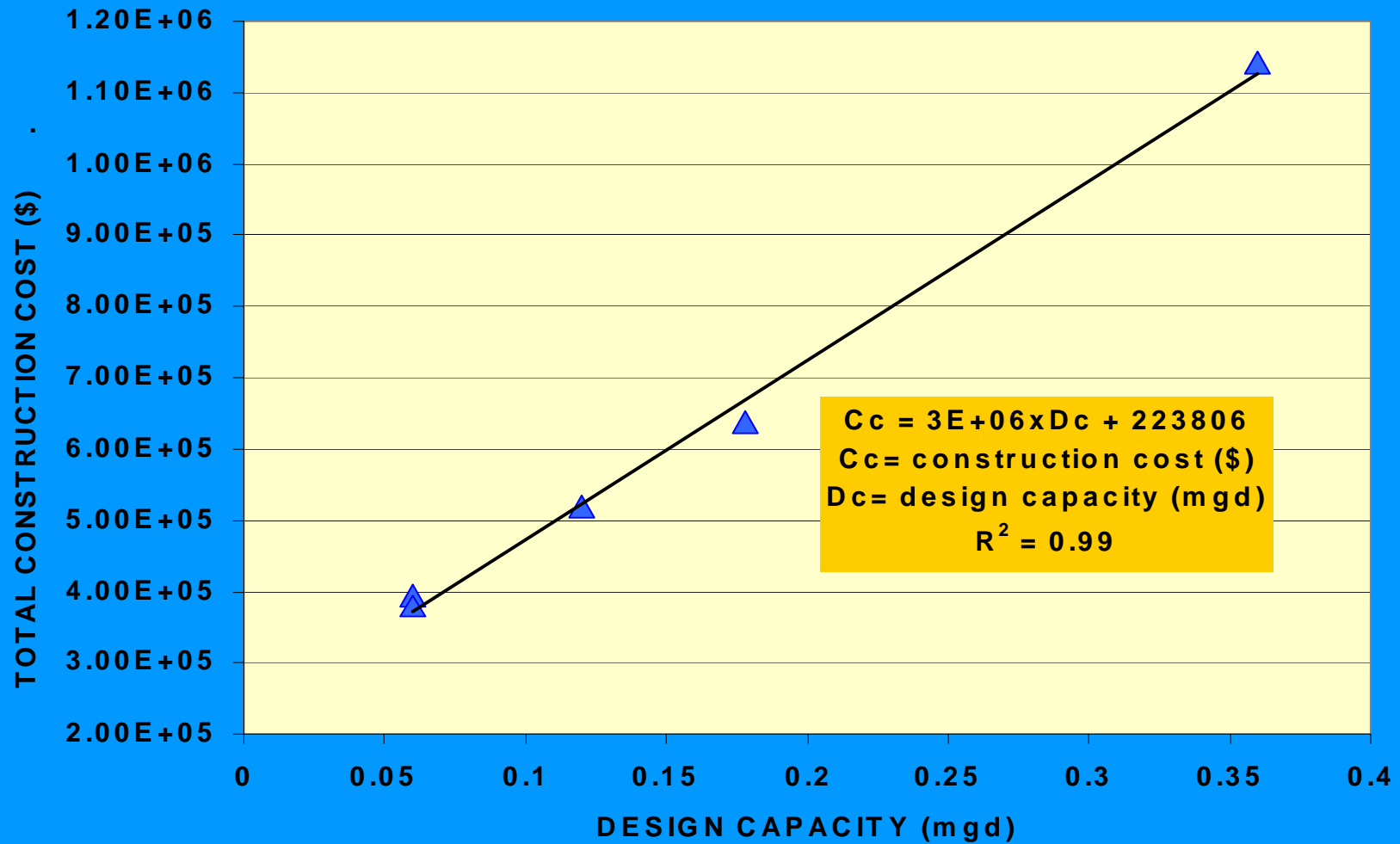

Unit Cost Versus Design Capacity

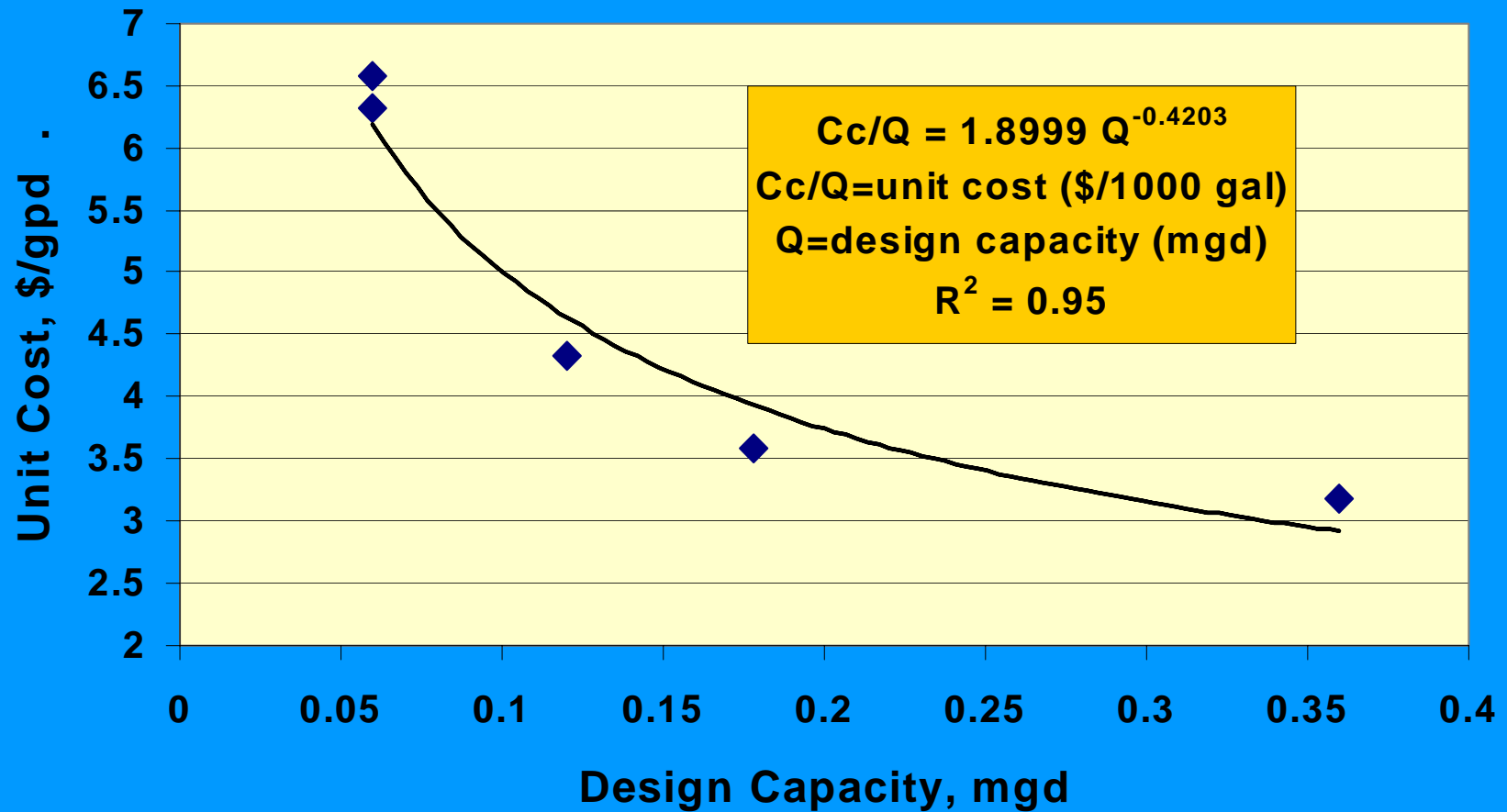

O&M COSTS

O&M Cost

Facility	Design Capacity (gpd)	Actual Treated Flow (gpd)	Total O&M budget (\$)	Normalized Budget \$/1000 gal
Contoocook	200,000	180,000	22,500	0.34

Modeled Slow Sand Filtration O&M Cost = \$0.30/1000 gal

Construction Costs Comparison

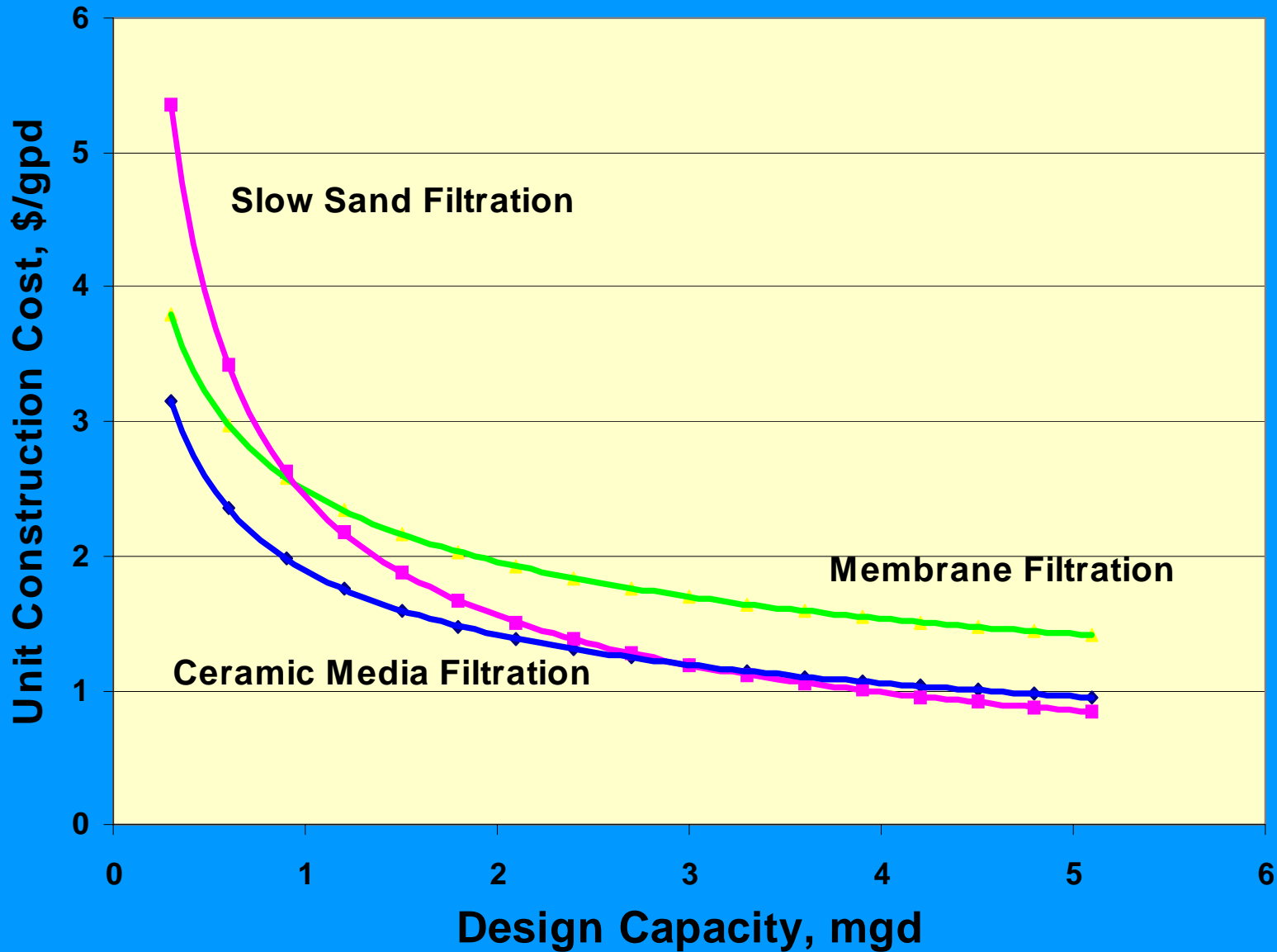

O&M Costs Comparison

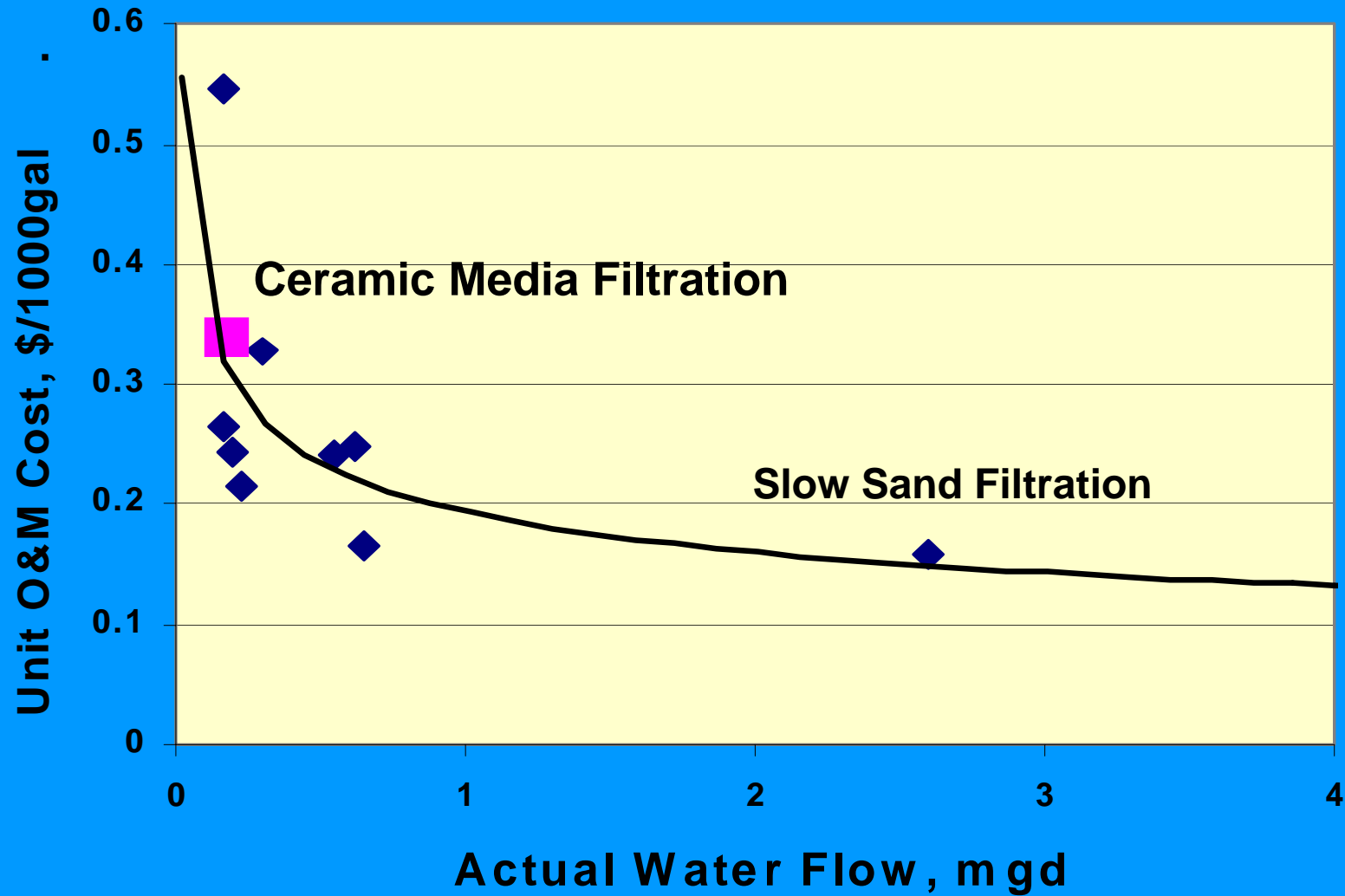

CONCLUSIONS

- Covered constructed slow sand filters
 - more expensive than ceramic media filters
 - more expensive than membrane filtration filters for small design capacities
 - cheaper alternative for larger capacities
- Not enough data collected to achieve an O&M cost comparison